

# Pegler

## Installation, Operating and Maintenance Instructions – 1250 DR Metering Station

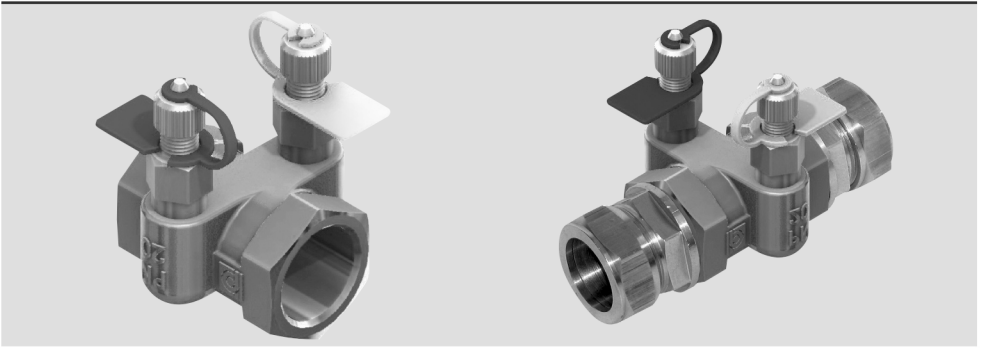

### The Pressure Equipment Directive 97/23/EC and CE Marking

The Pressure Equipment Regulations 1999 (SI 1999/2001) have now been introduced into United Kingdom law.

Valves with a maximum allowable pressure greater than 0.5 bar are covered by these new Regulations. Valves are categorised according to their maximum working pressure, size and rising level of hazard. The level of hazard varies according to the fluid being carried. Fluids are classified as Group 1, dangerous fluids or Group 2, all other fluids including steam. The Categories designated are SEP (sound engineering practice). Valves up to and including 25mm (1") are designated SEP regardless of the fluid group. Those identified as having increased hazard are Categorised as I, II, III or IV. All valves designated as SEP do not bear the CE mark nor require a Declaration of Conformity. Categories I, II, III or IV carries the CE mark and require a Declaration of Conformity. Valves classified from the piping chart would not be included in Category IV.

### Valve selection

It is important that the valve selected is suitable for the required service conditions. Provided it is installed correctly and receives adequate preventative maintenance it should give years of trouble-free service.

Pegler valves are not suitable for fatigue loading, creep conditions, fire testing, fire hazard

environment, corrosive or erosive service, or for carrying fluids containing abrasive solids. There is no allowance for corrosion in the design of these valves. Designs for this valve do not allow for decomposition of unstable fluids and must not be used where this could occur.

Pegler valves are not designed to withstand the effects of fire, wind, earthquakes and traffic.

When Pegler valves are fitted with pressure equipment or assemblies, suitable protective devices may be required.

#### Pegler 1250 DR Metering Station are suitable for:

Gas							
Steam	Water	Oil	Air	Inert	Combustible	Corrosive	Oxygen
X	✓	X	X	X	X	X	X

### Operational Limits

#### Pressure and temperature limitations for PN rated valves

PN	Connection	Non-shock pressure at temperature range	Non-shock pressure at Max temperature
16	Compression	16bar, 2°C - 30°C	5bar at 120°C
16	Tectite Push-fit	16bar, -10°C - 110°C	6bar at 95°C
16	XPress Press-fit	16bar, -10°C - 110°C	5bar at 120°C
20	Female thread	20bar, -10°C - 100°C	17.2bar at 120°C

#### Pegler 1250 DR Metering Station PED categorisation

1/2"	3/4"	1"	1 1/4"	1 1/2"	2"
S.E.P.	S.E.P.	S.E.P.	S.E.P.	S.E.P.	S.E.P.

CE marking is not required.

## Pressure/Temperature rating

Valves rated at PN16 and PN20 must be installed in a piping system whose normal pressure and temperature do not exceed the indicated ratings. The maximum allowable pressure in valves as specified in the standards is for non-shock conditions. Water Hammer and impact should also be avoided.

If system testing will subject the valve to pressure in excess of the working pressure rating, this should be within the “shell test pressure for the body” to a maximum of 1.5 times the PN rating and conducted with the valve fully opened.

It may be hazardous to use these valves outside of their specified pressure and temperature limitations and also when not used for the correct application.

## Valve location and end-of-line service

To ensure ease of operation, adjustment, maintenance and repair, valve siting should be decided during the system design phase. To prevent straining on the valve seat, pipe work and valves must be adequately supported. These valves are **NOT** suitable for end of line service.

## Installation

Unpack the valve and check that the flow paths and valve threads are clean and free from debris.

Check the body markings and nameplate, where fitted, to ensure that the correct valve has been selected for installation. Before valve installation the pipe work to which the valve is to be connected should be inspected for cleanliness and freedom from debris.

Pegler 1250 Metering Stations may be fixed in vertical pipe work or horizontal pipe work.

The valve is marked with a directional flow arrow on the body. The valve will function correctly providing it is fitted so that the fluid transported follows the indicated flow direction.

Pegler Valves are manufactured to exacting standards and, therefore, should not be subjected to misuse. The following should be avoided:

- Careless handling of the valve – (valves should not be lifted using the hand wheel or the stem).
- Dirt and debris entering the valve through the end ports.
- Excessive force during assembly and hand wheel operation.

Use suitable hangers close to both ends of the valve in order to remove stresses transmitted by the pipe.

Confirm that the pipe threading length is correct to avoid excessive penetration of the pipe into the valve that would otherwise cause damage.

Thread depths for Pegler 1250 DR Metering Station

½"	¾"	1"	1¼"	1½"	2"
DN15	DN20	DN25	DN32	DN40	DN50
16.5mm	17.6mm	20.0mm	21.5mm	21.3mm	26.1mm

Care should be taken to apply jointing compound to the pipe only and not in the valve threads. Surplus compound will then be forced outwards and will not enter the valve. Overuse of compound can lead to valve failure on the body ends.

Threads should be engaged correctly when tightening the valve onto the pipe. The wrench should always be fitted on the body end adjacent to the joint being made. Severe damage can occur to stems, valves and seats by the use of hand wheels or levers larger than those originally supplied by the manufacturer, and by wheel keys.

Valve options include pre-assembled with adaptors for Compression, Press fitting and Push fittings.

Compression joints should be made with Kuterlite joints that are suitable for Copper, stainless steel tube and carbon steel tube (15mm to 28mm). Joints should be made to hand tight and then further tightened as follows:

360° turn for 6mm - 12mm and 270° turn for 15mm - 54mm. A few drops of light oil on the threads will assist, on sizes 35mm and above.

All tightening should be carried out using a close fitting spanner. The larger size fittings may require a drop of light oil to aid joint tightening.

Press fit valves include the Xpress connectors and these are bronze and are suitable for copper tube, stainless steel and carbon steel tube. The Joints are of the leak before press type and utilise the M press profile.

Push fit valves utilise the Tectite connectors that also incorporate a special grab ring to allow connection to copper, carbon steel and stainless steel tube.

The Pegler 1250 Metering Station can be used in conjunction with the Pegler 1200DRV but the design does not allow for close coupling. It is important that when they are used in conjunction the Pegler 1200DRV the test points are positioned to allow for the easy use of manometer probes.

When measuring the flow an upstream straight length of tube should be a minimum of 3 pipe diameters to allow for lamina flow and more accurate measurement of the valve signal.

Straight pipe lengths are not necessary downstream of the 1250 Metering Station

## Operation – 1250 Metering Station Valve

The 1250 Metering Station is a device containing fixed orifice with two test points. The Test points are positioned to allow a measurement to be taken each side of the fixed orifice. This signal is used to provide flow data for system balancing and commissioning.

## Maintenance

Under normal working conditions Pegler 1250 valves do require maintenance.

Separate means of draining the pipe work must be provided when carrying out any maintenance to the valves.

Where there may be any system debris this should be collected and / or filtered by installation of the appropriate protective device.

Before starting work, de-pressurise the system, turn off any circulating pumps.

Prior to any inspection all valves should be at zero pressure and at ambient temperature.

## Product life span

When a valve is properly selected for its service conditions it should give years of trouble-free service provided it is installed correctly and receives adequate preventative maintenance. By not considering the compatibility of the system design and the pressure and temperature requirements the life expectancy of the valves can be adversely affected and valve failure may occur. The nature of the fluid being carried through the valve could also affect the valve performance as this could lead to premature valve failure. There may also be interactions between metals in the pipe system and the valve which need to be considered. Appropriate flushing and cleaning of the pipe work installation should take place when commissioning the system as they would help extend the valve life.

Stress corrosion cracking (SCC) is a phenomenon that occurs occasionally with brass compression fittings.

It is almost always introduced during installation, either from over-tightening of fittings

or contamination from a corrosive substance. The usual corrosive substance involved in SCC is ammonia or ammoniacal compounds, which can be found in cleaning fluids, refrigeration gases, sewage waste products, building materials, insulating materials (especially foams) and flame and smoke retarding treatments. An essential ingredient in the SCC process is moisture. Moisture on the fitting or pipework allows the corrosive substance to collect and become more concentrated. This is a particular problem in chilled water installations, where insulating materials allow the condensed moisture to be retained and kept in close contact with the fitting surface.

Pegler Yorkshire does not recommend the use of brass components in chilled water applications. Instead, we recommend fittings made from SCC resistant or immune materials, such as copper or gunmetal. Fittings from our XPress, Tectite, Yorkshire or Endex ranges are the preferred products for chilled water applications. If compression fittings are used then they should be assembled exactly in accordance with our published instructions and securely bound by a moisture barrier such as Densotape® to prevent moisture build up on the fitting. The following installation practices should be adhered to when installing compression fittings in order to avoid SCC:

1. Do not overtighten brass components.
2. Use correctly fitting spanners.
3. Use a drop or two of light oil on the threads of fittings of sizes 35mm and above.
4. Avoid contaminating the threads or nuts with jointing compounds.
5. Use parallel threaded adaptors to avoid stressing the female threaded ends.

Minimise the risk of contamination from a potential corrosive substance. Wrapping susceptible fittings in a vapour barrier or applying impermeable paints can be helpful in preventing contact with a corrosive substance.

Reference Material: Pegler Commercial Valves Package Brochure, Pegler Yorkshire Group Limited website.

A technical file is held at Doncaster as part of the requirements for compliance to the European Pressure Equipment Directive (PED 97/23 EC).

Our brands:

VSH Tectite

VSH XPress

VSH PowerPress

VSH Shurjoint

VSH MultiPress

Pegler Terrier

Pegler ProFlow

Pegler Valve

Pegler Prestex

Prestex

Yorkshire

Endex

Kuterlite



**UK ENQUIRIES**

**Free Phone:** 0800 156 0010

**Fax:** 01302 560 203

**Email:** uk.sales@aalberts-ips.com

**TECHNICAL HELP**

**Free Phone:** 0800 156 0050

**Email:** technical@aalberts-ips.com

**EXPORT**

**Phone:** +44 (0) 1302 855 656

**Email:** export@aalberts-ips.com

[www.pegler.co.uk](http://www.pegler.co.uk)

**Aalberts Integrated Piping Systems Ltd**

St. Catherine's Avenue, Doncaster,  
South Yorkshire, DN4 8DF, England

**Tel:** +44 (0) 1302 560 560

**Fax:** +44 (0) 1302 560 203

**Email:** info@pegler.co.uk

Registered in England Company No. 00401507 Registered  
Office: Haigh Park Road, Stourton, Leeds, West Yorkshire,  
LS10 1RT, England.

All brand names and logo styles are registered trademarks.  
Maintaining a policy of continual product development, Pegler  
reserves the right to change specifications, design and  
materials of products listed in this publication without prior  
notice.